

KOBAN



EN 60519-1:2011
EN 60519-2:2006
EN 61000-3-2:2006/A2:2009
EN 61000-3-3:2008
EN 55014-1:2006/A2:2011



CHARACTERISTICS

Operating voltage	120-250V AC/DC
Heating element	PTC resistor, self regulating and temperature limiting
Heater body	extruded aluminum profile, anodized
Connection casing	3 perssure clamps for stranded wire 0.5-1.5mm 2(with wire and terrule) and rigid wire 0.5-2.5mm 2plastic according to UL94 V-0, black
Mounting	clip for 35mm DIN rail, EN 50022
Fitting position	vertical
Operating/Storage temperature	-45 to +70 °C (-49 to +158°F)
Protection degree/Protection class	IP20/I (earthed)

Type	Code	Heating capacity	Inrush current max.	Length(L)	Weight (approx)
KH 75-15	0190123	15W	1.5	75mm	0.3kg
KH 75-30	0190124	30W	3	75mm	0.3kg
KH 75-45	0190125	45W	3.5	75mm	0.3kg
KH 75-60	0190112	60W	2.5	75mm	0.3kg
KH 75-75	0190126	75W	4	75mm	0.3kg
KH 145-100	0190127	100W	4.5	145mm	0.5kg
KH 145-150	0190128	150W	9	145mm	0.5kg

Calentadores

DIMENSIONS (mm)

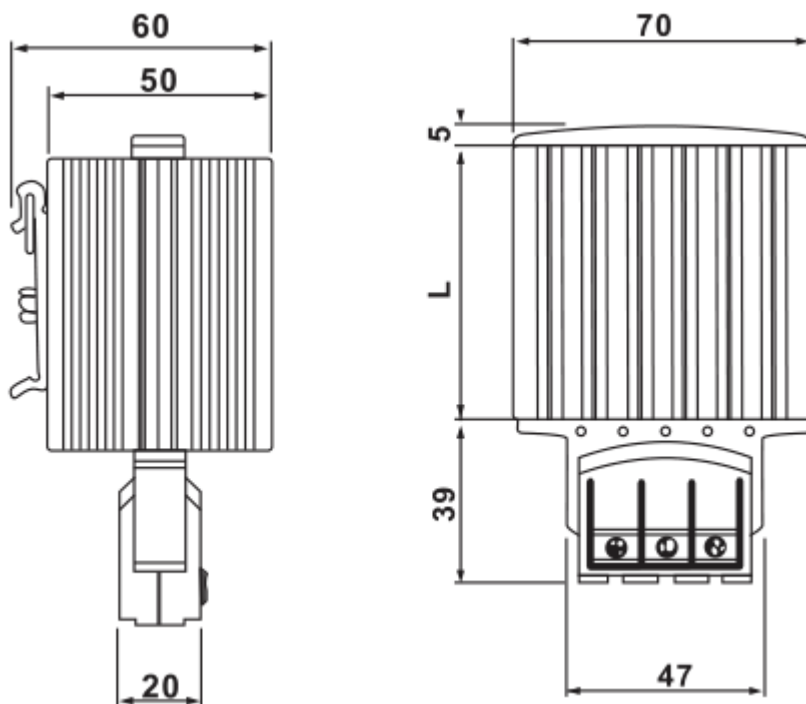

CONNECTION

